

HL-300
LED/Metal Halide
Raised Heliport Floodlighting

Heliport Floodlight is used for night operation. Shall be located so as to avoid glare to pilots in flight or personnel working on the area. Floodlighting system ensure the helipad surface illumination not less than 10 Lux.

Applications:

- Elevated mounted illuminated TLOF/FATO area.
- Winching areas.
- Parking areas.

Compliant:

- ICAO Annex 14, Volume II, 4th Edition, July, 2013
- FAA AC150/5390-2C

Why HL-300:

- Lens hood reduce the glare to pilots.
- Light source available in LED or metal halide lamp.
- UV stabilized toughened glass lens cover.
- Built-in surge protection device.
- Optical lens to design produce more efficiency beams.

LED &Electrical Characteristics:

- Luminous flux 1500Lm/LED, 8000Lm/Metal halide.
- Power by 220V~240V AC, 50Hz or 60 Hz.
- LED 15 Watts, Metal halide 70 Watts.
- Color temperature 4500K.

Overall Size Drawing:

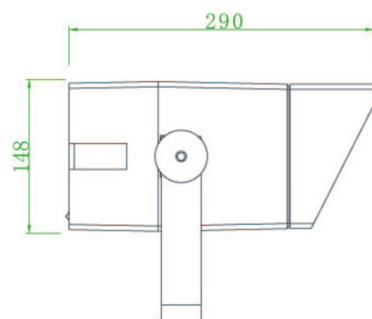
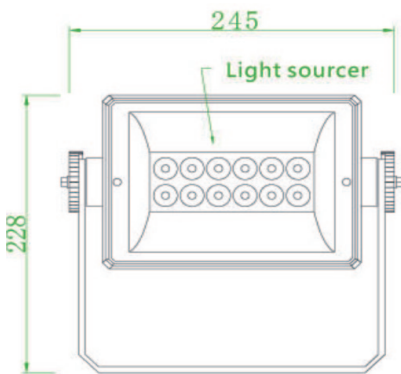

Physical Characteristics:

- Casting aluminum alloy housing.
- Gray powder coating finish.
- Toughened glass lens cover.
- Overall size: 24.5cm×29cm×22.8cm. (9.6''×11.4''×9'')
- 8cm-M8×2 for mounting details.
- 4.6KG net weight.
- IP65 ingress protection.

Environmental:

- Operating at -40°C to 55 °C.
- Wind speed: 80m/s.
- Humidity: 0 to 100%.

Ordering codes:

Type	Output	Lamp	Lamp hood
HL-300	W: White	L: LED Type MH: Metal Halide Type	Default included.

Mounting Size:

